

Company Name : _____
公司名称 : _____

Attention to : _____
客户联系人 : _____

Date : **2020-10-16**
日期 : _____

Product Specification 产品规格书

Product Name : **EDLC MODULE**
产品名称 : _____

Part Number : **MPBT0101203060016AC**
产品型号 : _____

Version : **A0**
版本 : _____

Document No. : _____
文件编号 : _____

Customer			
Approved	Approved	Checked	Prepared
<Company Stamp > <公司盖章处>			

Forward Electronics (Dongguan) Co., Ltd. 富华德电子东莞有限公司		
Approved	Checked	Prepared
潘武洲	邬树厅	邬树厅
2020-10-16	2020-10-16	2020-10-16

Revision History
规格书修订记录

Version 版本	Date 日期	Page 页码	Revision 变更内容	Prepared by 编写	Remark 备注
A0	2020-10-16	11	Original release 初版发行	ST WU 邬树厅	

CONTENTS 目录

一、Scope 适用范围 4

二、Specification 主要技术参数 4

三、EDLC Module EDLC 模组 6

 3.1 Main Component 主要部件 6

 3.2 Appearance & Structure 外观和结构 6

四、Product General Performance 产品常规性能 7

五、Product Reliability 产品可靠性 7

六、Product Circuit 产品电路 7

 6.1 Circuit Diagram 电路原理图 7

 6.2 CMS Parameters 电容管理系统参数 7

 6.3 Balance Board Drawing 均衡板图纸 8

七、Charge/Discharge Characteristics 充放电特性 8

八、Product Dimensions 产品尺寸 9

十、 Notice 注意事项 10

 10.1 Charging 充电 10

 10.2 Discharging 放电 11

 10.3 Storage 储存 11

一、Scope 适用范围

This specification applies to the 30V 1F EDLC module.

本规格书适用于 30V 1F EDLC 模组产品。

二、Specification 主要技术参数

NO. 序号	Items 项目	Specification 规格	Remark 备注
1	Rated Capacitance 额定容量	1F (-10%~30%)	Measuring method: see Note below 测试方法见下述说明
2	Rated Voltage 额定电压	30V	U_R
3	Surge Voltage 最高电压	32V	
4	Internal Resistance (AC) 交流内阻	$\leq 450m\Omega$	Measuring frequency 测试频率: 1kHz Measuring temperature 测试温度: $20\pm 2^\circ C$
5	Internal Resistance (DC) 直流内阻	$\leq 800m\Omega$	
6	Standard Charging Current 标准充电电流	0.12A	-25~45 $^\circ C$ 4* $C U_R$ (mA) CC (Constant Current) charge to U_R , then cut off after CV (Constant Voltage U_R) charging for 30min. -25~45 $^\circ C$ 4* $C U_R$ (mA) 电流恒流充电到 U_R , 然后恒压 30 分后截至。
7	Max Charging Current 最大充电电流	2.5A	5sec charge to U_R 5sec 充电到 U_R
8	Standard Discharging Current 标准放电电流	0.12A	-25~45 $^\circ C$ 4* $C U_R$ (mA) CC (Constant Current) discharge to $U_R/2$. -25~45 $^\circ C$ 4* $C U_R$ (mA) 电流恒流放电到 $U_R/2$ 。
9	Max Discharging Current 最大放电电流	2.5A	5sec discharge to $U_R/2$. 5sec 放电到 $U_R/2$ 。
10	最大峰值放电电流 Max. Peak Current	5A	1sec discharge to $U_R/2$. 1sec 放电到 $U_R/2$ 。
11	Energy capacity(Fully Charged)最大存储能量	0.125Wh	At U_R
12	Leakage Current 漏电流	$\leq 0.15m A$	After 24 hours at 25 $^\circ C$. 25 $^\circ C$, 24 小时后。
13	Operating Temperature Range 工作温度范围	-40~70 $^\circ C$	
14	Storage Temperature Range 储存温度范围	-40~70 $^\circ C$	
15	Nominal Weight 重量	Approx 0.3kg	
16	Protection Class 防护等级	IP20	

Note 说明

Constant current discharge method 恒流放电测试方法:
 Measuring circuit 测试线路示意:

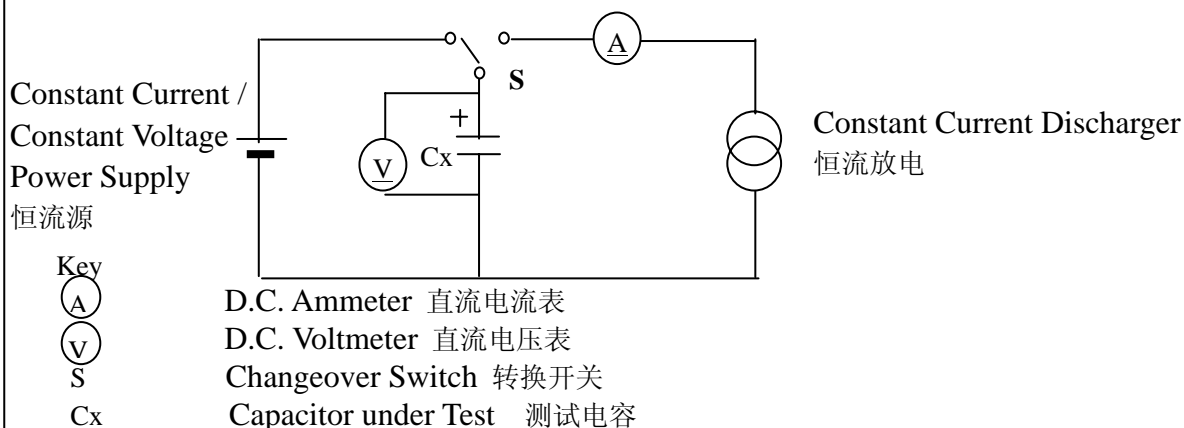

Figure 1: Circuit for Constant Current Discharge Method 图 1: 恒流放电方法线路

Measuring method 测试方法

- 1) Set the D.C. voltage at the rated voltage (U_R). 设定恒流源的电压在额定值。
- 2) Set the constant current value of the constant current discharger to the discharge current specified in Table 1. 按照表1的要求设定负载仪的放电电流。
- 3) Turn the switch S to the D.C. power supply, apply voltage and charge for 30 min after the constant current/constant voltage power supply has achieved the rated voltage. 将转换开关拨到恒流源充电端, 恒流充电达到额定电压值后, 再恒压充电30分。
- 4) After charging for 30 min, change over the switch S to the constant current discharger, and discharge with a constant current. 30分充电结束后, 转换开关拨到负载仪端, 进行恒流放电。
- 5) Measure the time t_1 and t_2 when the voltage between capacitor terminals at the time of discharge reduces from U_1 to U_2 as shown in Figure 2, and calculate the capacitance value by the following formula:

如图 2 所示, 记录放电时电压在 U_1, U_2 的时刻, t_1, t_2 的值, 并用以下公式计算容量。

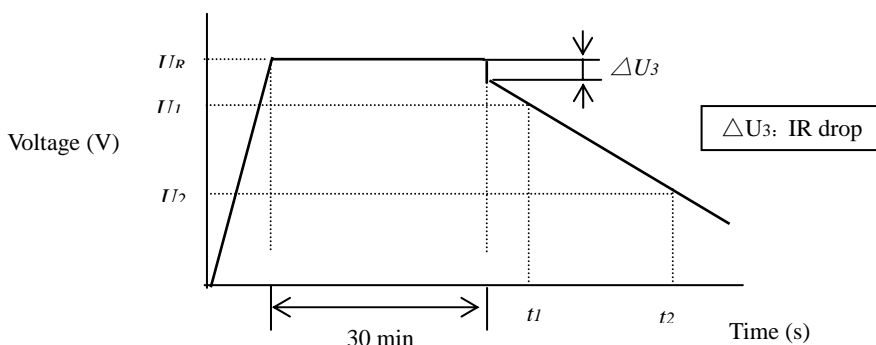

Figure 2: Voltage Characteristics between Capacitor Terminals 图 2: 电容器端电压特征

$$C = \frac{I_x(t_2-t_1)}{U_1-U_2}$$

- C the capacitance (F); 容量 (F)。
- I the discharge current (A); 放电电流 (A)。
- U_1 the measurement starting voltage (V); 测量开始时电压 (V)。

- U_2 the measurement ending voltage (V); 测量结束时电压 (V)。
- t_1 the time from discharge start to reach U_1 (s); 放电开始到电压达到 U_1 的时间 (s)。
- t_2 the time from discharge start to reach U_2 (s); 放电开始到电压达到 U_2 的时间 (s)。
- U_R the rated voltage for the EDLC module (V); EDLC 模块的额定电压 (V)。

6) The discharge current I and the voltages U_1 and U_2 at the time of discharge voltage drop shall be as per Table 1. The method classification shall be in accordance with the individual standards.
 放电电流和 U_1 , U_2 的压降按照表 1 制定。

Table 1: Discharge Conditions 表 1: 放电条件

Charge Time 充电时间	30 min
I (mA)	$4 \times CU_R$
U_1	The value to be 80% of the charging voltage ($0.8 \times U_R$) 额定电压值的 80%。
U_2	The value to be 40% of the charging voltage ($0.4 \times U_R$) 额定电压值的 40%。
NOTE: C_R is the rated capacitance in F (Farad), and U_R is the rated voltage in V (Volt). 注: C_R 是额定容量, 单位法拉 (F); U_R 是额定电压, 单位伏特 (V)。	

三、EDLC Module EDLC 模组

3.1 Main Component 主要部件

NO. 序号	Items 项目	Specification 规格	Quantity 数量	Remark 备注
1	Cell 单体电容	DRL 2.7V 12F	12pcs	Φ 12.5*25mm RR
2	Balance board 均衡板	30V 1F FW-VMS-12S01P-01 A0	1pc	
3	Terminal 端子线	AWG 16#, Red and Black	2pcs	“+”、“-”
4	PET 套管		1pc	

3.2 Appearance & Structure 外观和结构

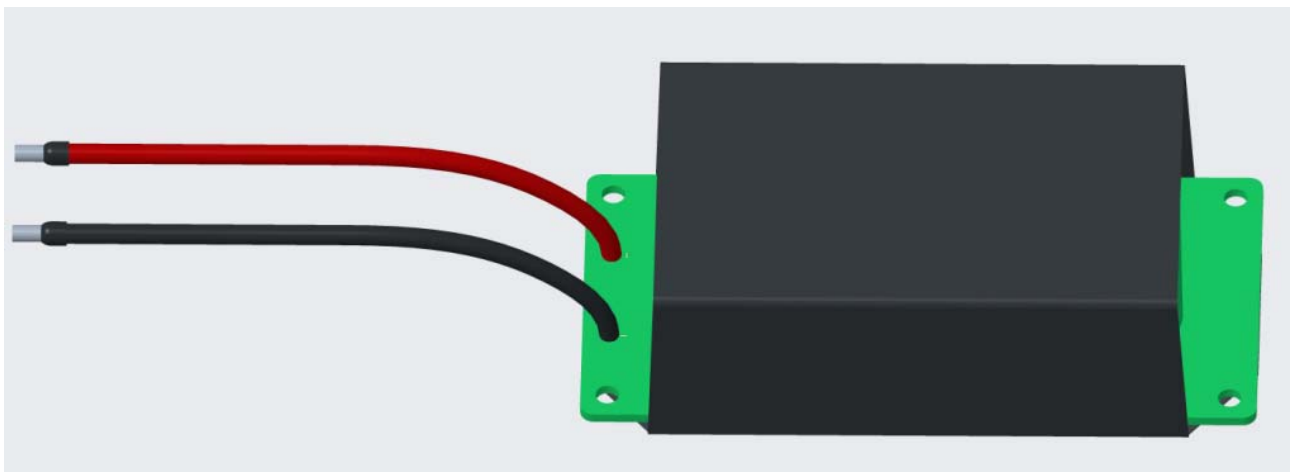

四、Product General Performance 产品常规性能

No. 序号	Items 项目	Criteria 标准	Test Method 测试方法
1	Load Life Test 寿命测试	$\Delta C/C$: 初始电容的 $\pm 30\%$ 范围内 ESR: 初始电容的 ESR*2.0.	The capacitor is stored at temperature $70 \pm 2 \text{ }^\circ\text{C}$ with rated voltage for 1000 +48/-0 hours. The result should meet the specifications without visible damage and no leakage of electrolyte. 在额定电压下, 在 $70 \pm 2 \text{ }^\circ\text{C}$ 条件下储存 1000 +48/-0 小时, 满足容量和 ESR 标准, 同时无可见损伤, 无电解液泄漏。
2	Cycle Life (20°C)	$\geq 500,000$ Cycles	Constant current charging to the rated voltage, constant discharge to half rated voltage. 恒流充电到额定电压 U_R , 恒流放电到 $1/2U_R$
3	Temperature Characteristics 温度特性	-40°C $\Delta C/C$: 初始电容的 $\pm 30\%$ 范围内 ESR: 初始电容的 ESR*2.0.	Measuring method: see Note above 测试方法见前述说明
		70°C $\Delta C/C$: 初始电容的 $\pm 30\%$ 范围内 ESR: 初始电容的 ESR*2.0.	

五、Product Reliability 产品可靠性

No. 序号	Items 项目	Criteria 标准	Test Method 测试方法
1	Temperature and Humidity Test 温湿度测试	$\Delta C/C$: 初始电容的 $\pm 20\%$ 范围内 小于等于初始电容的 ESR*4.0.	The capacitor shall be exposed for 240 ± 48 hours in an atmosphere of 90~95%RH at $40 \pm 2 \text{ }^\circ\text{C}$, the characteristic change shall meet the following requirement. The result should meet the specifications without visible damage and no leakage of electrolyte. 将电容在湿度 90~95%RH, 温度 $40 \pm 2 \text{ }^\circ\text{C}$ 的条件下放置 240 ± 48 小时, 满足容量和 ESR 标准, 同时无可见损伤, 无电解液泄漏。

六、Product Circuit 产品电路

6.1 Circuit Diagram 电路原理图

(略)

6.2 CMS Parameters 电容管理系统参数

电阻被动均衡

6.3 Balance Board Drawing 均衡板图纸

(略)

七、Charge/Discharge Characteristics 充放电特性

Charge: $4C_{UR}$ (0.12A) CC (Constant Current) charge to 30V, then cut off after CV (Constant Voltage) charging for 30min.

充电: 0.12A 恒流充电到 30V, 然后恒压 30 分钟截至。

Discharge: $4C_{UR}$ (0.12A) CC (Constant Current) discharge to 15V。

放电: 0.12A 恒流放电到 15V。

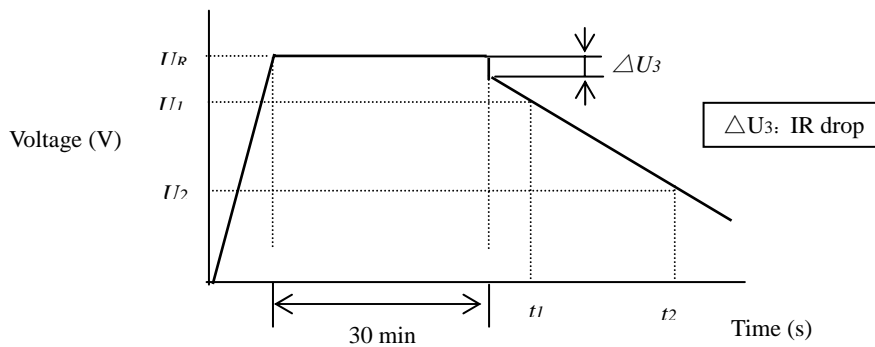

八、Product Dimensions 产品尺寸

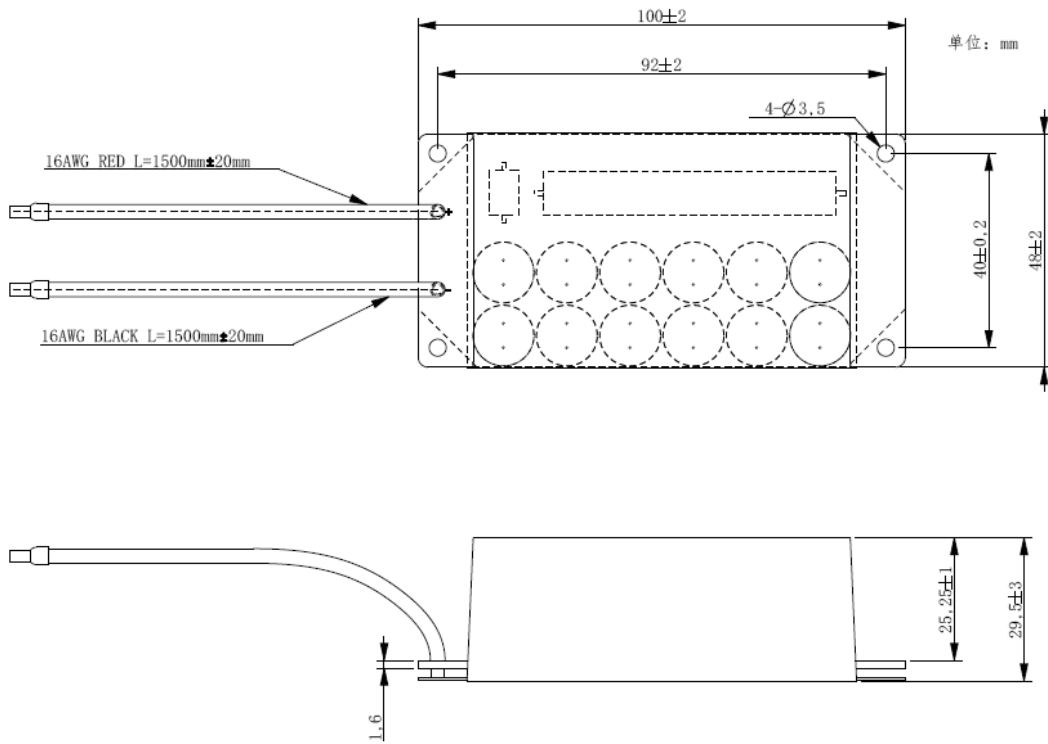

九、Product Label 产品标签

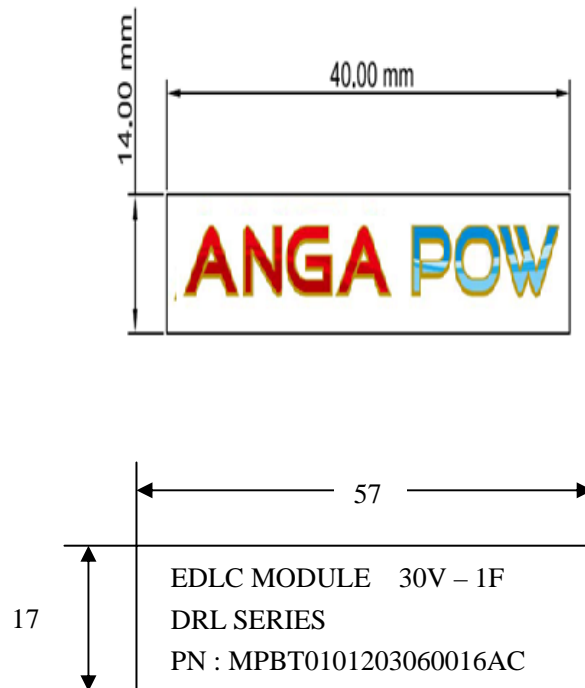



十、Notice 注意事项

10.1 Charging 充电

10.1.1 Charging Current 充电电流

Charging current should be less than maximum charge current specified in the product specification. Charging with higher current than recommended value may cause damage to cell performance in electrical and mechanical characteristics as well as safety, and could lead to head generation or leakage.

充电电流不得超过本规格书最大的充电电流，使用高于充电值充电将可能引起电容的充放电性能，机械性能和安全性能的问题，可能导致发热或泄漏。

10.1.2 Charging Voltage 充电电压

Charging shall be done at voltage less than what specified (30V) in the product specification. Charging beyond 32V, which is the absolute maximum voltage, must be strictly prohibited. The charger shall be designed to comply with this condition.

充电电压不得高过本规格书规定的额定电压（30V），32V 为充电最高极限，充电器的设计应满足此条件。

Charging with higher voltage than recommended value may cause damage to cell performance in electrical and mechanical characteristics as well as safety, and could lead to head generation or leakage.

充电电压高于额定电压值，可能引起电容的充放电性能，机械性能，和安全性能的问题，可能会导致发热或泄露。

10.1.3 Charging Temperature 充电温度

The module shall be charged within -40~70°C.

产品必须在-40~70°C温度范围内进行充电。

10.1.4 Prohibition of Reverse Charging 禁止反向充电

Positive and negative poles of the module should be connected correctly, and reverse charging is prohibited. The reverse charging may cause damage to the module, leading to degradation of module performance.

正确的连接模块的正负极，严禁反向充电，反向充电会降低模块的充放电性能。

10.2 Discharging 放电

10.2.1 Discharging Current 放电电流

The module shall be discharged at less than the maximum discharge current specified in the product specification. High discharging current may reduce the discharging capacity rapidly and cause over-heat.

放电电流不得超过规格书规定的最大放电电流，大电流放电会导致容量快速下降和过热。

10.2.2 Discharging Temperature 放电温度

The module shall be discharged within $-40\sim 70^{\circ}\text{C}$.

产品必须在 $-40\sim 65^{\circ}\text{C}$ 温度范围内进行放电。

10.3 Storage 储存

10.3.1 The capacitor cannot be stored in place with humidity over 85%RH or place with toxic gas.

产品不能储存在湿度超过 85%，或有毒气体的地方。

10.3.2 The capacitor should be best stored in the environment within $-20\sim 50^{\circ}\text{C}$ temperature with relative humidity less than 60%.

最好储存在温度 $-20\sim 50^{\circ}\text{C}$ ，湿度 60%的环境中。